

| ALUMINUM EXTRUSIONS | | | | | | |
|--|-----------------|----|-------|-------|-------------|-------------|
| PART # | DIMENSIONS (IN) | | | | LENGTH (FT) | FINISHES |
| | e | a | t | r | | |
| CCRIC1729 | 1 1/2 | 2 | 1/8 | 0.125 | 20 | MILL FINISH |
| CCRIC1754 | 2 | 3 | 1/4 | 0.188 | 20 | MILL FINISH |
| CCRIC1755 | 2 | 4 | 3/16 | 0.375 | 20 | MILL FINISH |
| CCRIC1756 | 1 1/2 | 3 | 1/4 | 0.312 | 20 | MILL FINISH |
| CCRIC1757 | 2 | 6 | 0.281 | 0.437 | 20 | MILL FINISH |
| CCRIC1776 | 3 | 8 | 9/32 | 0.500 | 20 | MILL FINISH |
| CCRIC1778 | 2 1/2 | 6 | 1/4 | 0.437 | 20 | MILL FINISH |
| CCRIC1782 | 3 1/2 | 10 | 5/16 | 0.562 | 20 | MILL FINISH |
| CUSTOM FINISHES AVAILABLE FOR ALL EXTRUSIONS | | | | | | |

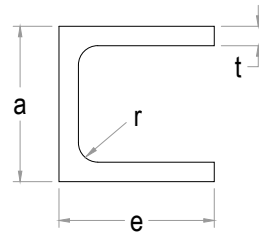

END VIEW

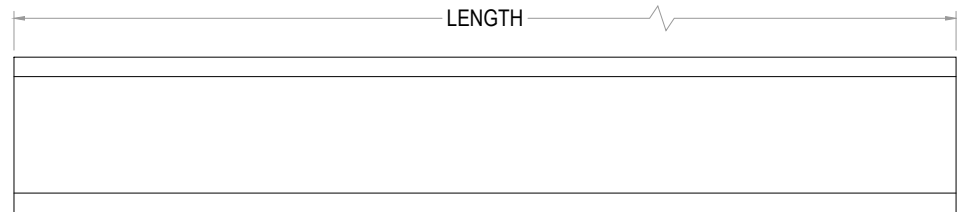

SIDE VIEW

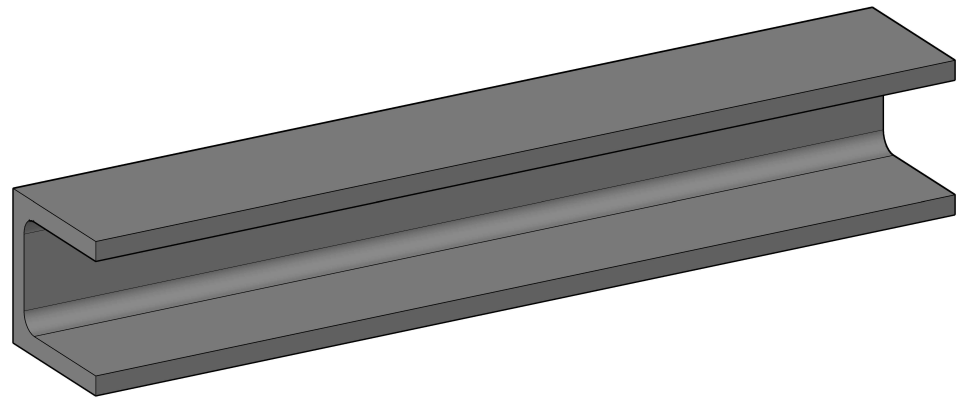

ISOMETRIC VIEW



Decorative
Wall
Panels

<https://DWPanels.com>

© 2017 DWPANELS, LLC

Information In This Drawing is Provided for Reference Only

PART NUMBER:
CCRIC1729, CCRIC1754-CCRIC1757, CCRIC1776
CCRIC1778, CCRIC1782

PART NAME:
C CHANNEL ROUNDED INSIDE CORNER